



# MULTI-ROOM DUCTLESS HEAT-PUMP SYSTEMS

30000 BTU / H WALL MOUNTED HEAT- PUMP SYSTEM

## SUBMITTAL DATA: TM30H40

Job Name	Location	Date
Purchaser	Engineer	
Submitted To	For	<input type="checkbox"/> Reference <input type="checkbox"/> Approval <input type="checkbox"/> Construction
Unit Designation	Schedule No.	

**AHRI CERTIFIED REF  
10064021 (NON-DUCTED) &  
10064022 (DUCTED)**



SYSTEM RATINGS		OUTDOOR UNIT DATA	
<b>Non-Ducted Indoor</b>		<b>Compressor</b>	
Rated Cooling Capacity	28,400 BTUH	Type	DC Inverter Driven Rotary
Cooling Capacity (min-max)	8,189-33,438 BTUH	RLA	13.9 A
Rated Heating Capacity	30,00 BTUH	<b>Compressor Crankcase and Base Pan Heaters included</b>	
Heating Capacity (min-max)	8,189-32,414 BTUH	<b>Fan Motor</b>	
SEER/EER	21.0/12.5	Output Power	100 W
HSPF/COP	11.5/3.7	FLA	0.7 A
<b>Ducted Indoor</b>		Air Flow (Max)	2,354 CFM
Rated Cooling Capacity	28,400 BTUH	<b>Sound Pressure Level</b>	
Cooling Capacity (min-max)	6,200-30,800 BTUH	Cooling	59 dB(A)
Rated Heating Capacity	30,000 BTUH	Heating	59 dB(A)
Heating Capacity (min-max)	6,500-32,500 BTUH	<b>Dimensions &amp; Weights</b>	
SEER/EER	16.0/10.5	Unit Dimensions (LxHxD)	38.4 x 31.0 x 17.3 -in
HSPF/COP	8.5/3.3	Weight (Net/Shipping)	154.0/169.4 LBS
<b>Operating Range</b>		Min. Number of Indoor Units	1
Cooling (min-max)	0 ~ 118°F	Max. Number of Indoor Units	4
	-18 ~ 48°C	<b>REFRIGERANT PIPING DATA</b>	
Heating (min-max)	-5 ~ 86°F	Refrigerant Type	R410A
	-21 ~ 30°C	Refrigerant Charge	98.7 oz
<b>Power Supply</b>		Additional Charge Per Line Length	0.21-oz/ft
Normal Operational Voltage	208/230 V, 1 Phase, 60 Hz	Connection Method	Flared
Voltage Range	187 - 253 V	Factory Charge for Total Line Length	131-ft
Main Power Wire Size	10-2 AWG	Total Refrigerant Pipe Length	230-ft
Interconnecting Cable Wire Size	14-4 AWG	Max Refrigerant Piping Length to any Indoor Unit	82-ft
MCA	20 A	Min Refrigerant Piping Length to any Indoor Unit	10-ft
MOCP/Breaker Size	30 A	Max Elevation between Indoor Units	25-ft
		Max Lift from Outdoor to Indoor Unit	49-ft
		Max Drop from Outdoor to Indoor Unit	49-ft

### GENERAL FEATURES

- Up to 4 Indoor Units(4-Port)
- EnergyStar Rated
- G10 DC Inverter Technology
- Quiet Operation - Both Indoor & Outdoor
- Acrylic Resin/Anti-Corrosion Coil Protection
- Intelligent Defrost
- Auto Restart on Power Outages
- Multi-point Diagnostics

TOSOT.COM





## FEATURES & FUNCTION SUMMARY: TM30H40

SYSTEM FEATURES	
Inverter Type	G10
Ultra Low Frequency Torque Control	YES
Power Factor Correction	YES
Compressor Type	Inverter Rotary
Refrigerant Type	R410A
Basepan With Electric Heater	YES
Compressor With Electric Heater	YES
Condenser Fan	Axial
Condenser Motor Type	DC
Condenser Motor Drive	Direct
Condenser Coil	Aluminum Fin/Copper Tube
Outdoor Fin Coating (Blue)	Acrylic Resin
Intelligent Defrosting	YES
Low Voltage Startup	YES
Memory/Power Failure Recovery	YES
Self Diagnosis	YES
Low Ambient Cooling	YES
XK19 Wired Controller Interface	YES
<b>REMOTE CONTROLLER FUNCTIONS</b>	<b>See individual Indoor Unit Controllers Functions</b>
XK19 WIRED CONTROLLER FUNCTIONS <sup>2</sup>	
On/Off	YES
Operating Mode	YES
Fan Speed	YES
Room Setpoint	YES
Model Numbers	YES
Timer Mode	YES
Sleep Mode	YES
Turbo Mode	YES
X-Fan Mode	YES
Privacy Lock	YES

Note: Some indoor models may not support specific system features or functions.

**TOSOT**

## DIMENSIONAL SPECIFICATIONS: TM30H40

### 30,000 BTUH MODEL

Model # TM30H40 30,000 BTUH 230V

Units: inch

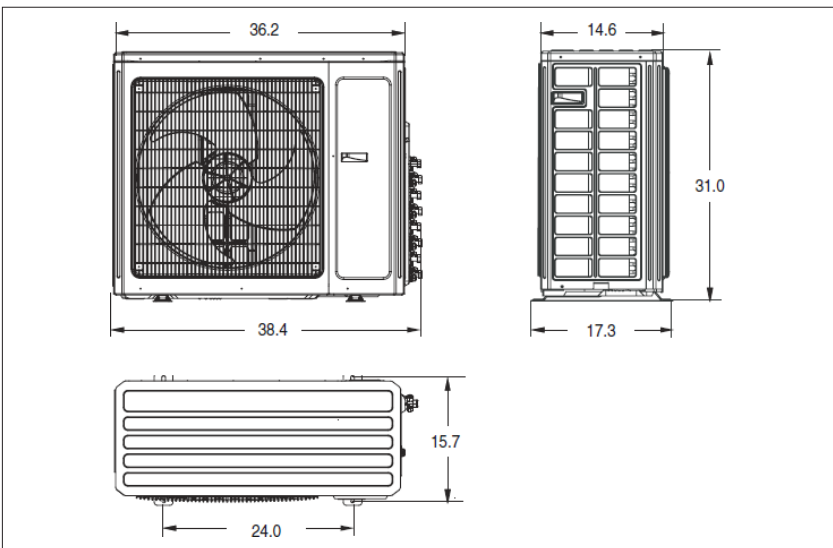

#### Suction/Gas Line Port Size

Port A	3/8-in OD Flared
Port B	3/8-in OD Flared
Port C	3/8-in OD Flared
Port D	3/8-in OD Flared

#### Liquid Line Port Size

Port A	1/4-in OD Flared
Port B	1/4-in OD Flared
Port C	1/4-in OD Flared
Port D	1/4-in OD Flared

#### Factory Supplied Piping Adapters

Adapter	P/N	Qty
3/8 (F) to 5/8 (M)	6654100009	2
3/8 (F) to 1/2 (M)	6654100013	4
1/4 (F) to 3/8 (M)	6654104	2

### MINIMUM SPACING REQUIREMENTS

Units: inch

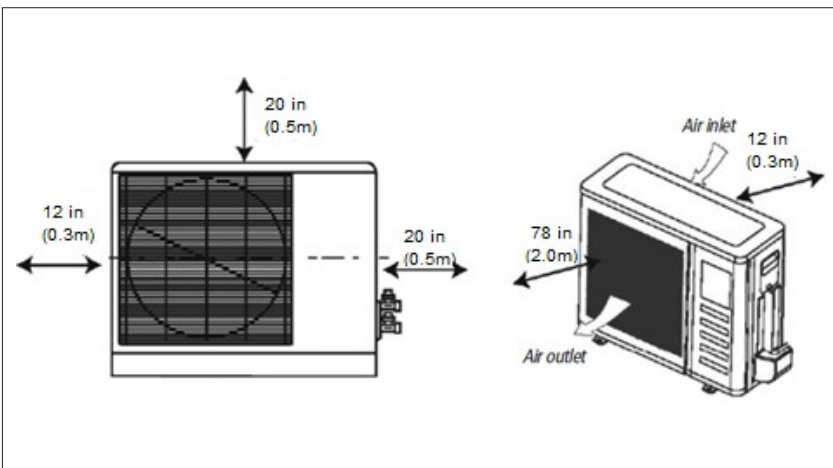

#### Notes:

1. Recommended Interconnecting Cable Type  
14 AWG 4 Stranded Copper Conductors Wire.
2. Power wiring cable size must comply with applicable national and local codes.
3. Test conditions are based on AHRI 210/240.



## OPERATIONAL PERFORMANCE SPECIFICATIONS: TM30H40

COOLING CAPACITY (BTUH)					
Indoor Units Combinations	Rated System Capacity (BtuH)	Indoor Unit A (BtuH)	Indoor Unit B (BtuH)	Indoor Unit C (BtuH)	Indoor Unit D (BtuH)
9+9	18,000	9,000	9,000	NA	NA
9+12	21,000	9,000	12,000	NA	NA
9+18	22,950	7,650	15,300	NA	NA
9+24	27,780	7,380	20,400	NA	NA
12+12	24,000	12,000	12,000	NA	NA
12+18	25,500	10,200	15,300	NA	NA
12+24	28,860	9,420	19,440	NA	NA
18+18	28,360	14,180	14,180	NA	NA
18+24	29,100	12,000	17,100	NA	NA
9+9+9	25,500	8,500	8,500	8,500	NA
9+9+12	26,200	8,000	8,000	10,200	NA
9+9+18	29,800	7,650	7,650	14,500	NA
9+9+24	29,800	6,300	6,300	17,200	NA
9+12+12	28,200	8,200	10,000	10,000	NA
9+12+18	29,600	7,000	8,600	14,000	NA
12+12+12	28,500	9,500	9,500	9,500	NA
12+12+18	30,200	8,600	8,600	13,000	NA
9K + 9K + 9K + 9K	29,600	7,400	7,400	7,400	7,400
9K + 9K + 9K + 12K	29,700	7,100	7,100	7,100	8,400
9K + 9K + 12K + 12K	29,600	6,800	6,800	8,000	8,000

Capacity data is based on the following conditions :

Cooling Nominal Test Conditions	Heating Nominal Test Conditions
Indoor: 80°F DB/67°F WB	Indoor: 70°F DB/60°F WB
Outdoor: 95°F DB/75°F WB	Outdoor: 47°F DB/43°F WB



## OPERATIONAL PERFORMANCE SPECIFICATIONS: TM30H40

Indoor Units Combinations	Rated System Capacity (BtuH)	Indoor Unit A (BtuH)	Indoor Unit B (BtuH)	Indoor Unit C (BtuH)	Indoor Unit D (BtuH)
9+9	19,000	9,500	9,500	NA	NA
9+12	22,500	9,500	13,000	NA	NA
9+18	25,380	8,460	16,920	NA	NA
9+24	30,840	8,280	22,560	NA	NA
12+12	26,000	13,000	13,000	NA	NA
12+18	28,200	11,280	16,920	NA	NA
12+24	29,900	9,900	20,000	NA	NA
18+18	30,200	15,100	15,100	NA	NA
18+24	31,800	13,300	18,500	NA	NA
9+9+9	28,500	9,500	9,500	9,500	NA
9+9+12	28,800	8,800	8,800	11,200	NA
9+9+18	31,100	7,900	7,900	15,300	NA
9+9+24	31,500	6,750	6,750	18,000	NA
9+12+12	28,900	8,500	10,200	10,200	NA
9+12+18	30,700	7,200	9,000	14,500	NA
12+12+12	29,700	9,900	9,900	9,900	NA
12+12+18	31,500	9,000	9,000	13,500	NA
9K + 9K + 9K + 9K	30,800	7,700	7,700	7,700	7,700
9K + 9K + 9K + 12K	31,300	7,300	7,300	7,300	9,400
9K + 9K + 12K + 12K	31,600	6,800	6,800	9,000	9,000

Capacity data is based on the following conditions :

Cooling Nominal Test Conditions	Heating Nominal Test Conditions
Indoor: 80°F DB/67°F WB	Indoor: 70°F DB/60°F WB
Outdoor: 95°F DB/75°F WB	Outdoor: 47°F DB/43°F WB



## EXTENDED RATINGS: TM30H40

COOLING PERFORMANCE													
DB WB		Indoor Ambient Temperature											
		70°F (21°C)			75°F (24°C)			80°F (27°C)			90°F (32°C)		
		59°F (15°C)			63°F (17°C)			67°F (19°C)			73°F (23°C)		
		TC (BtuH)	SC (BtuH)	Input Power (watts)	TC (BtuH)	SC (BtuH)	Input Power (watts)	TC (BtuH)	SC (BtuH)	Input Power (watts)	TC (BtuH)	SC (BtuH)	Input Power (watts)
Outdoor Ambient Temperature (DB)	-4°F (-18°C)	17,230	13,510	1,050	19,430	15,240	1,110	20,540	16,110	1,150	23,150	18,150	1,230
	5°F (-15°C)	17,670	13,860	1,050	19,930	15,630	1,120	21,320	16,720	1,150	23,730	18,620	1,230
	14°F (-10°C)	18,500	14,510	1,060	20,870	16,370	1,120	22,060	17,300	1,160	24,860	19,490	1,240
	23°F (-5°C)	20,270	15,900	1,060	23,090	18,110	1,120	24,840	19,490	1,150	27,330	21,430	1,230
	32°F (0°C)	20,368	17,612	1,430	23,281	19,840	1,430	25,621	21,538	1,699	26,748	25,005	1,612
	41°F (5°C)	21,413	18,515	1,503	24,474	20,857	1,503	26,935	22,643	1,786	28,119	26,288	1,695
	50°F (10°C)	22,305	19,287	1,566	25,494	21,726	1,566	28,057	23,586	1,860	29,291	27,383	1,765
	59°F (15°C)	23,500	20,320	1,650	26,860	22,890	1,650	29,560	24,850	1,960	30,860	28,850	1,860
	68°F (20°C)	24,520	21,135	1,736	27,550	23,714	1,760	30,313	25,704	2,009	31,228	29,201	2,025
	77°F (25°C)	28,631	23,264	2,108	31,071	25,502	2,111	33,852	27,389	2,365	37,373	28,573	2,402
	86°F (30°C)	30,859	24,172	2,826	33,084	26,134	2,853	35,179	32,712	2,905	39,601	29,290	2,955
	95°F (35°C)	28,914	23,131	3,099	31,218	25,298	3,121	33,654	26,154	3,206	37,012	28,522	3,267
104°F (40°C)	22,851	20,906	2,566	24,550	22,872	2,583	26,052	24,462	2,773	28,321	25,171	2,668	
113°F (45°C)	17,839	17,658	2,172	19,214	19,057	2,207	25,738	25,110	2,835	21,800	21,387	2,244	
118°F (48°C)	13,700	13,628	1,708	15,030	14,908	1,762	16,634	16,382	1,896	17,770	17,433	1,867	

HEATING PERFORMANCE													
DB WB		Indoor Ambient Temperature											
		70°F (21°C)			75°F (24°C)			80°F (27°C)			90°F (32°C)		
		59°F (15°C)			63°F (17°C)			67°F (19°C)			73°F (23°C)		
		TC (BtuH)	Input Power (watts)	COP	TC (BtuH)	Input Power (watts)	COP	TC (BtuH)	Input Power (watts)	COP	TC (BtuH)	Input Power (watts)	COP
Outdoor Ambient Temperature (DB)	-5°F (-21°C)	18,126	1,620	3.28	17,756	1,650	3.15	17,059	1,680	2.98	16,652	1,710	2.85
	0°F (-18°C)	18,500	1,650	3.29	17,960	1,680	3.13	17,630	1,740	2.97	17,160	1,780	2.83
	5°F (15°C)	19,510	1,720	3.32	18,950	1,750	3.17	18,590	1,820	2.99	18,110	1,860	2.85
	7°F (14°C)	20,010	1,750	3.35	19,050	1,790	3.12	19,360	1,870	3.03	18,860	1,920	2.88
	17°F (8°C)	20,940	1,790	3.43	20,330	1,830	3.26	19,950	1,900	3.08	19,420	1,940	2.93
	28°F (2°C)	23,660	1,910	3.63	23,040	1,950	3.46	22,380	2,020	3.25	22,110	2,070	3.13
	38°F (3°C)	29,420	2,200	3.92	28,800	2,240	3.77	28,140	2,330	3.54	27,870	2,380	3.43
	47°F (8°C)	33,250	2,290	4.26	32,240	2,330	4.06	31,600	2,420	3.83	30,730	2,480	3.63
	57°F (14°C)	34,350	2,330	4.32	33,310	2,380	4.10	32,650	2,470	3.87	31,740	2,520	3.69
	68°F (20°C)	35,750	2,410	4.35	34,660	2,460	4.13	33,970	2,550	3.90	33,030	2,610	3.71
	77°F (25°C)	36,580	2,470	4.34	35,470	2,520	4.13	34,760	2,620	3.89	33,800	2,680	3.70

LEGEND:	DB - Dry Bulb
	WB --- Wet Bulb
	TC --- Total Capacity (BtuH)
	SC --- Sensible Capacity (BtuH)
	Input Power---(Watts)
	COP---Coefficient Of Performance

\* Maximum system capacity TC- Total Capacity ( BtuH) COP- Coefficient of Performance