

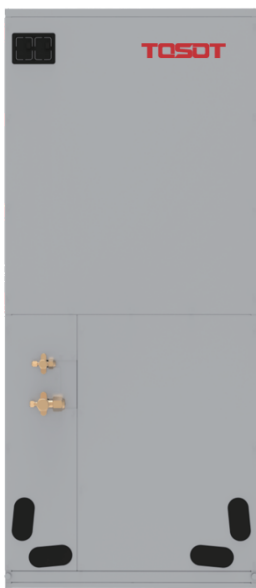

UNIX SEER16
AIR DUCTED SYSTEM

**TECHNICAL SALES
GUIDE**



MODELS:

TUD24W2/D-D(U)
TUD30W2/D-D(U)
TUD36W2/D-D(U)
TUD42W2/D-D(U)
TUD48W2/D-D(U)
TUD60W2/D-D(U)



CONTENTS

1 PRODUCT LIST	1
2 NOMENCLATURE	3
3 PRODUCT FEATURES.....	4
4 PRODUCT DATA.....	5
5 FAN CHARACTERISTICS	13
6 DIMENSION	15
7 WIRING DIAGRAM	21

1 PRODUCT LIST



1.1 Outdoor Unit

Model	Power Supply	Product Code	Appearance
	V/Ph/Hz		
TUD24W2/D-D(U)	208/230V-1Ph-60Hz	CF090W2280	
TUD30W2/D-D(U)	208/230V-1Ph-60Hz	CF090W2300	
TUD36W2/D-D(U)	208/230V-1Ph-60Hz	CF090W2290	
TUD42W2/D-D(U)	208/230V-1Ph-60Hz	CF090W2310	
TUD48W2/D-D(U)	208/230V-1Ph-60Hz	CF090W2270	
TUD60W2/D-D(U)	208/230V-1Ph-60Hz	CF090W2410	

1.2 Indoor Unit

	Model	Cooling/Heating Capacity (Btu/h)	Power Supply	Product Code	Appearance
			V/Ph/Hz		
Air handler	TUD24AH2/D-D(U)	23000/23000	208/230V-1Ph-60Hz	EH010N0130	
Air handler	TUD30AH2/D-D(U)	28600/28600	208/230V-1Ph-60Hz	EH010N0160	
Air handler	TUD36AH2/D-D(U)	34000/34000	208/230V-1Ph-60Hz	EH010N0140	
Air handler	TUD42AH2/D-D(U)	40000/40000	208/230V-1Ph-60Hz	EH010N0150	
Air handler	TUD48AH2/D-D(U)	46000/46000	208/230V-1Ph-60Hz	EH010N0120	
Air handler	TUD60AH2/D-D(U)	54000/54000	208/230V-1Ph-60Hz	EH010N0170	

2 NOMENCLATURE

TU	D	24	W	2	D	D	(U)
1	2	3	4	5	6	7	8

NO.	Description	Options
1	Product code	TOSOT U-Match
2	Motor type	Omit = AC motor; D=DC motor
3	Cooling capacity code	Nominal capacity (kBtu/h)
4	Unit type	W=Outdoor unit; AH= High pressure air handler
5	Communication protocol	Omit = 485 communication(include outdoor unit without main board; control outdoor unit by strong electricity); 1= Power line communication; 2=24V communication; 3=Other communication
6	Design number	Named in order of A, B, C, or combined with 1, 2, 3...
7	Power supply	D=208/230V ~60Hz
8	Designed for market	U=North America

3 PRODUCT FEATURES

➔ 3.1 Description

TOSOT R410A DC inverter u-match series air conditioners have combined the extraordinary comfort of the central air conditioners with the convenient installation and facility of the mini type of the split air conditioners. It is equipped with the condenser coil constructed of the hydrophilic aluminum fin and the inner groove copper pipe, and also the low-noise compressor with various protections on the high/low pressure, high discharge temperature, overload, and the sensor malfunction alarm. The casing of this unit is made of pre-painted steel, capable of resisting corrosion and rust creep and ensuring minimal fading when exposed to sunlight.

TOSOT R410A DC inverter u-match series air conditioning units can offer the perfect combination of superior product quality, high operating efficiency and cost efficiency. The capacity rated according to AHRI 210/240-2023 ranges from 24kBu/h to 60kBu/h, which could be sufficient to different requirements from customers. These units have achieved UL certificate. All units are factory tested prior to dispatch to verify the operation performance and control functioning.

The unit can set for heating even when the outdoor ambient temperature drops to -15°C (5°F) and thus an ideal for locations that require heating in winter. The careful design from each part to the whole unit, together with the all-round process test and unit test, offers the high reliability for the whole system.

Perfect system protections can guarantee the safety of the system at utmost and get rid of the irreparable damage to the compressor or other critical parts under the harsh working conditions.

➔ 3.2 Features-Outdoor Units

- ◆ 24V control enables the third party 24V thermostat. The outdoor unit can auto adjust capacity intelligently without communication.
- ◆ Compact side discharge design occupies half area than that of conventional top discharge design, which is highly suitable for constricted application. It can be installed either on the ground or on the wall to save more space.

➔ 3.3 Indoor Units



DC INVERTER ROOFTOP PACKAGED AIR CONDITIONERS

Airflow Patterns for Extra Comfort:

It can connect many supply-air outlets to the duct, so that it can make the temperature and humidity of the whole room even. All units are provided with filters that they are easily accessible from the rear of the unit.

Flexible Installation:

Air-supply or air-return type, condensation water exit direction etc can be selected flexibly.

Easy Maintenance:

Evaporator coils are constructed of quality inner groove copper tube and hydrophilic aluminum fin. It adopts easy and reliable configuration design, so maintenance is very convenient and easy.



Versatile Functions:

- ◆ Time display function
- ◆ Timer function
- ◆ Memory function
- ◆ °F /°C switch function
- ◆ Temperature display function
- ◆ E-heater function
- ◆ 4-way valve energizing function
- ◆ Temperature compensation function

4 PRODUCT DATA

➔ 4.1 Product Data at Rated Condition

Air Handler

Model	Indoor Unit		TUD24AH2/D-D(U)	TUD30AH2/D-D(U)	TUD36AH2/D-D(U)	TUD42AH2/D-D(U)	TUD48AH2/D-D(U)	TUD60AH2/D-D(U)
	Product Code		EH010N0130	EH010N0160	EH010N0140	EH010N0150	EH010N0120	EH010N0170
	Outdoor Unit		TUD24W2/D-D(U)	TUD30W2/D-D(U)	TUD36W2/D-D(U)	TUD42W2/D-D(U)	TUD48W2/D-D(U)	TUD60W2/D-D(U)
	Product Code		CF090W2280	CF090W2300	CF090W2290	CF090W2310	CF090W2270	CF090W2410
Capacity	Cooling	Btu/h	23000	28600	34000	40000	46000	54000
	Heating	Btu/h	23000	28600	34000	40000	46000	54000
Power Input	Cooling	kW	2.30	2.86	3.07	4.08	5.41	5.36
	Heating	kW	2.30	2.86	3.41	4.22	5.41	5.15
SEER 2/ HSPF2		—	15.50/7.80	15.20/7.80	15.50/7.70	15.50/7.80	15.00/7.70	15.20/7.80

Indoor Unit			TUD24AH2/D-D(U)	TUD30AH2/D-D(U)	TUD36AH2/D-D(U)	TUD42AH2/D-D(U)	TUD48AH2/D-D(U)	TUD60AH2/D-D(U)
Power Supply		—	208/230V-1Ph-60Hz					
Fan	Drive	—	Direct	Direct	Direct	Direct	Direct	Direct
	Motor Output	kW	0.37×1	0.37×1	0.37×1	0.37×1	0.75×1	0.75×1
	Air Flow	m³/h (CFM)	1360 (800)	1530 (900)	1785 (1050)	2091 (1230)	2380 (1400)	2550 (1500)
	Rated Ext. Static Pressure	Pa (InWg)	125 (0.50)	125 (0.50)	125 (0.50)	125 (0.50)	125 (0.50)	125 (0.50)
	Ext. Static Pressure Range	Pa (InWg)	0~250 (0-1.0)	0~250 (0-1.0)	0~250 (0-1.0)	0~250 (0-1.0)	0~250 (0-1.0)	0~250 (0-1.0)
Sound Pressure Level (H/M/L)		dB(A)	47	51	51	53	53	54
Air Filter		—	Metal	Metal	Metal	Metal	Metal	Metal
Drain Piping		mm (inch)	Φ25.4×1.2 (Φ1×0.05)	Φ25.4×1.2 (Φ1×0.05)	Φ25.4×1.2 (Φ1×0.05)	Φ25.4×1.2 (Φ1×0.05)	Φ25.4×1.2 (Φ1×0.05)	Φ25.4×1.2 (Φ1×0.05)
Outline Dimensions (W×D×H)		mm (inch)	460×540×1105 (18-1/8×21-1/4×43-1/2)	460×540×1105 (18-1/8×21-1/4×43-1/2)	540×540×1224 (21-1/4×21-1/4×48-3/16)	540×540×1224 (21-1/4×21-1/4×48-3/16)	630×540×1320 (24-13/16×21-1/4×51.968)	630×540×1320 (24-13/16×21-1/4×51.968)
Net Weight		kg (lb)	57.0 (125.7)	57.0 (125.7)	70.0 (154.3)	70.0 (154.3)	86.0 (189.6)	86.0 (189.6)
Outdoor Unit			TUD24W2/D-D(U)	TUD30W2/D-D(U)	TUD36W2/D-D(U)	TUD42W2/D-D(U)	TUD48W2/D-D(U)	TUD60W2/D-D(U)
Power Supply		—	208/230V-1Ph-60Hz					
Heat Exchange		—	Inner Groove Copper Tube-Aluminum Fin					
Compressor	Type	—	Rotary	Rotary	Rotary	Rotary	Rotary	Rotary
	Power Input	W	1480	2020	2293	2293	2293	4580
Refrigerant	Control	—	Electronic Expansion Valve	Electronic Expansion Valve	Electronic Expansion Valve	Electronic Expansion Valve	Electronic Expansion Valve	Electronic Expansion Valve
	Charge	kg (oz)	2.0 (70.6)	2.2 (77.6)	3.0 (105.8)	3.5 (123.5)	4.5 (158.8)	5.6 (197.6)
Outline Dimensions (W×H×D)		mm (inch)	889×340×658 (35×13-3/8×25-7/8)	923×370×746 (36-5/16×14-9/16×29-3/8)	923×370×746 (36-5/16×14-9/16×29-3/8)	943×370×826 (37-1/8×14-9/16×32-1/2)	943×370×826 (37-1/8×14-9/16×32-1/2)	990×370×960 (39×14-9/16×37-13/16)
Net Weight		kg (lb)	45.0 (99.225)	54.0 (119.07)	60.1 (132.52)	69.0 (152.1)	74.5 (164.2)	91.0 (200.6)
Piping Connections	Liquid	Inch	Φ3/8	Φ3/8	Φ3/8	Φ3/8	Φ3/8	Φ3/8
	Gas	Inch	Φ3/4	Φ3/4	Φ3/4	Φ3/4	Φ3/4	Φ3/4
	Max. Length	m (ft)	30 (98.4)	30 (98.4)	50 (164.0)	50 (164.0)	50 (164.0)	50 (164.0)
	Max. Height	m (ft)	15 (49.2)	15 (49.2)	30 (98.4)	30 (98.4)	30 (98.4)	30 (98.4)

DC INVERTER ROOFTOP PACKAGED AIR CONDITIONERS

NOTES:

- a. The design of this unit conforms to the requirements of AHRI 210/240-2023 standard.
- b. The air flow is measured at the rated external static pressure.
- c. Cooling (heating) capacity stated above is measured under nominal working conditions corresponding to rated external static pressure. The parameters are subject to change with the improvement of products, in which case the values on nameplate shall prevail.

—		Indoor	Outdoor
Cooling		DB: 26.7°C(80.0°F) WB: 19.4°C(67.0°F)	DB: 35.0°C(95.0°F) WB: 23.9°C(75.0°F)
Heating		DB: 21.1°C(70.0°F) WB: 15.6°C(60.0°F)	DB: 8.33°C(47.0°F) WB: 6.11°C(43.0°F)
Piping Length	24k~60k units	7.5m(24.6ft)	

➔ 4.2 Operation Range

Mode	Range of Outdoor Temperature
Cooling	-15.0°C(5.0°F)~ 48.0°C(114.8°F)
Heating	-15.0°C(5.0°F)~24.0°C(75.2°F)

➔ 4.3 Cooling Performance

NOTES:

PI: Power input
 DB: Dry Bulb Temperature; WB: Wet Bulb Temperature
 TC: Total Capacity; SHC: Sensible Heat Capacity

Air Handler
 TUD24W2/D-D(U)

Indoor air temperature °C		Outdoor dry bulb temperature °C														
		20			25			30			35			40		
		TC	SHC	PI	TC	SHC	PI	TC	SHC	PI	TC	SHC	PI	TC	SHC	PI
DB	WB	kW	kW	kW	kW	kW	kW	kW	kW	kW	kW	kW	kW	kW	kW	kW
20	14	5.80	3.92	1.24	6.24	4.22	1.65	6.31	4.26	2.01	5.97	4.04	2.12	5.73	3.87	2.21
23	16	6.20	4.46	1.30	6.68	4.80	1.73	6.75	4.86	2.10	6.39	4.60	2.22	6.13	4.41	2.32
26	18	6.51	4.87	1.34	7.01	5.24	1.78	7.09	5.30	2.17	6.71	5.02	2.29	6.44	4.82	2.38
27	19	6.54	4.94	1.34	7.05	5.31	1.79	7.12	5.37	2.18	6.74	5.08	2.30	6.47	4.88	2.40
30	22	6.87	5.34	1.38	7.40	5.75	1.84	7.48	5.81	2.24	7.08	5.50	2.37	6.79	5.28	2.47
32	24	7.22	5.84	1.42	7.77	6.29	1.89	7.85	6.35	2.31	7.43	6.01	2.44	7.13	5.77	2.54

TUD30W2/D-D(U)

Indoor air temperature °C		Outdoor dry bulb temperature °C														
		20			25			30			35			40		
		TC	SHC	PI	TC	SHC	PI	TC	SHC	PI	TC	SHC	PI	TC	SHC	PI
DB	WB	kW	kW	kW	kW	kW	kW	kW	kW	kW	kW	kW	kW	kW	kW	kW
20	14	7.21	4.39	1.54	7.76	4.72	2.05	7.84	4.77	2.49	7.42	4.52	2.64	7.13	4.34	2.74
23	16	7.71	5.10	1.61	8.30	5.49	2.15	8.39	5.55	2.62	7.94	5.25	2.76	7.62	5.04	2.88
26	18	8.10	5.63	1.66	8.72	6.07	2.21	8.81	6.13	2.69	8.34	5.80	2.85	8.01	5.57	2.96
27	19	8.14	5.72	1.67	8.76	6.16	2.22	8.85	6.23	2.71	8.38	5.89	2.86	8.05	5.66	2.98
30	22	8.54	6.25	1.72	9.20	6.73	2.29	9.30	6.80	2.79	8.80	6.44	2.94	8.45	6.18	3.07
32	24	8.97	6.91	1.77	9.66	7.44	2.35	9.76	7.52	2.87	9.24	7.11	3.03	8.87	6.83	3.16

TUD36W2/D-D(U)

Indoor air temperature °C		Outdoor dry bulb temperature °C														
		20			25			30			35			40		
		TC	SHC	PI	TC	SHC	PI	TC	SHC	PI	TC	SHC	PI	TC	SHC	PI
DB	WB	kW	kW	kW	kW	kW	kW	kW	kW	kW	kW	kW	kW	kW	kW	kW
20	14	8.57	5.44	1.65	9.22	5.86	2.20	9.32	5.92	2.68	8.82	5.60	2.83	8.47	5.38	2.95
23	16	9.17	6.27	1.73	9.87	6.75	2.30	9.98	6.82	2.81	9.44	6.46	2.97	9.07	6.20	3.09
26	18	9.63	6.89	1.78	10.36	7.42	2.37	10.47	7.50	2.89	9.91	7.10	3.05	9.52	6.82	3.18
27	19	9.68	7.00	1.79	10.42	7.53	2.38	10.53	7.61	2.91	9.96	7.20	3.07	9.57	6.92	3.20
30	22	10.16	7.61	1.84	10.94	8.20	2.45	11.05	8.28	2.99	10.46	7.84	3.16	10.04	7.53	3.29
32	24	10.67	8.38	1.90	11.48	9.02	2.53	11.61	9.11	3.08	10.99	8.63	3.25	10.55	8.28	3.39

DC INVERTER ROOFTOP PACKAGED AIR CONDITIONERS

TUD42W2/D-D(U)

Indoor air temperature °C		Outdoor dry bulb temperature °C														
		20			25			30			35			40		
		TC	SHC	PI	TC	SHC	PI	TC	SHC	PI	TC	SHC	PI	TC	SHC	PI
DB	WB	kW	kW	kW	kW	kW	kW	kW	kW	kW	kW	kW	kW	kW	kW	kW
20	14	10.08	5.96	2.19	10.85	6.42	2.92	10.97	6.49	3.56	10.38	6.14	3.76	9.97	5.90	3.92
23	16	10.78	6.97	2.30	11.61	7.51	3.06	11.73	7.59	3.73	11.11	7.18	3.94	10.66	6.89	4.11
26	18	11.32	7.73	2.37	12.19	8.32	3.15	12.32	8.41	3.84	11.66	7.96	4.06	11.20	7.64	4.23
27	19	11.38	7.86	2.38	12.25	8.46	3.17	12.38	8.55	3.86	11.72	8.09	4.08	11.25	7.77	4.25
30	22	11.95	8.60	2.45	12.86	9.26	3.26	13.00	9.36	3.98	12.31	8.86	4.20	11.81	8.50	4.37
32	24	12.55	9.53	2.52	13.51	10.26	3.36	13.65	10.37	4.09	12.92	9.82	4.32	12.41	9.43	4.50

TUD48W2/D-D(U)

Indoor air temperature °C		Outdoor dry bulb temperature °C														
		20			25			30			35			40		
		TC	SHC	PI	TC	SHC	PI	TC	SHC	PI	TC	SHC	PI	TC	SHC	PI
DB	WB	kW	kW	kW	kW	kW	kW	kW	kW	kW	kW	kW	kW	kW	kW	kW
20	14	11.59	7.25	2.91	12.48	7.80	3.87	12.61	7.88	4.72	11.94	7.46	4.98	11.46	7.16	5.19
23	16	12.40	8.38	3.05	13.35	9.02	4.06	13.50	9.12	4.95	12.77	8.63	5.23	12.26	8.28	5.45
26	18	13.02	9.23	3.14	14.02	9.93	4.18	14.17	10.04	5.10	13.41	9.50	5.38	12.88	9.12	5.61
27	19	13.09	9.37	3.16	14.09	10.08	4.20	14.24	10.19	5.12	13.48	9.65	5.41	12.94	9.26	5.64
30	22	13.74	10.21	3.25	14.80	10.99	4.32	14.95	11.11	5.27	14.15	10.51	5.57	13.59	10.09	5.80
32	24	14.43	11.25	3.35	15.54	12.11	4.45	15.70	12.24	5.43	14.86	11.58	5.73	14.27	11.12	5.97

TUD60W2/D-D(U)

Indoor air temperature °C		Outdoor dry bulb temperature °C														
		20			25			30			35			40		
		TC	SHC	PI	TC	SHC	PI	TC	SHC	PI	TC	SHC	PI	TC	SHC	PI
DB	WB	kW	kW	kW	kW	kW	kW	kW	kW	kW	kW	kW	kW	kW	kW	kW
20	14	13.61	8.15	2.88	14.65	8.77	3.83	14.81	8.87	4.67	14.02	8.39	4.94	13.46	8.06	5.14
23	16	14.56	9.51	3.02	15.68	10.23	4.02	15.84	10.34	4.90	15.00	9.79	5.18	14.40	9.40	5.40
26	18	15.29	10.52	3.11	16.46	11.33	4.14	16.64	11.45	5.05	15.75	10.83	5.33	15.12	10.40	5.56
27	19	15.37	10.69	3.13	16.54	11.51	4.16	16.72	11.63	5.07	15.83	11.01	5.36	15.19	10.57	5.58
30	22	16.14	11.69	3.22	17.37	12.59	4.28	17.56	12.72	5.22	16.62	12.04	5.52	15.95	11.56	5.75
32	24	16.94	12.94	3.32	18.24	13.93	4.41	18.43	14.08	5.38	17.45	13.33	5.68	16.75	12.80	5.92

4.4 Heating Performance

NOTES:

PI: Power input
 DB: Dry Bulb Temperature; WB: Wet Bulb Temperature
 TC: Total Capacity; SHC: Sensible Heat Capacity
 Air Handler
 TUD24W2/D-D(U)

Outdoor air temperature °C		Indoor dry bulb temperature °C									
		16		18		20		22		24	
		TC	PI	TC	PI	TC	PI	TC	PI	TC	PI
DB	WB	kW	kW	kW	kW	kW	kW	kW	kW	kW	kW
-10	-11	6.42	2.58	6.08	2.65	5.81	2.75	5.57	2.84	5.31	2.93
-5	-5.6	6.35	2.30	6.02	2.37	5.75	2.45	5.51	2.53	5.26	2.62
0	-0.7	6.53	2.27	6.19	2.33	5.91	2.42	5.67	2.50	5.40	2.58
7	6	7.44	2.16	7.06	2.22	6.74	2.30	6.46	2.38	6.16	2.46
10	8	7.88	2.23	7.47	2.29	7.13	2.37	6.84	2.45	6.52	2.53

DC INVERTER ROOFTOP PACKAGED AIR CONDITIONERS

TUD30W2/D-D(U)

Outdoor air temperature °C		Indoor dry bulb temperature °C									
		16		18		20		22		24	
		TC	PI	TC	PI	TC	PI	TC	PI	TC	PI
DB	WB	kW	kW	kW	kW	kW	kW	kW	kW	kW	kW
-10	-11	7.98	3.21	7.56	3.30	7.22	3.41	6.92	3.53	6.60	3.65
-5	-5.6	7.90	2.86	7.49	2.94	7.15	3.05	6.86	3.15	6.54	3.26
0	-0.7	8.12	2.82	7.70	2.90	7.35	3.00	7.05	3.10	6.72	3.21
7	6	9.26	2.69	8.77	2.76	8.38	2.86	8.03	2.96	7.66	3.05
10	8	9.79	2.77	9.28	2.85	8.87	2.95	8.50	3.04	8.10	3.15

TUD36W2/D-D(U)

Outdoor air temperature °C		Indoor dry bulb temperature °C									
		16		18		20		22		24	
		TC	PI	TC	PI	TC	PI	TC	PI	TC	PI
DB	WB	kW	kW	kW	kW	kW	kW	kW	kW	kW	kW
-10	-11	9.49	3.83	8.99	3.93	8.59	4.07	8.23	4.21	7.85	4.35
-5	-5.6	9.39	3.42	8.90	3.51	8.50	3.63	8.15	3.76	7.77	3.88
0	-0.7	9.65	3.37	9.15	3.46	8.74	3.58	8.38	3.70	7.99	3.82
7	6	11.01	3.20	10.43	3.29	9.96	3.41	9.55	3.52	9.11	3.64
10	8	11.64	3.30	11.04	3.39	10.54	3.51	10.11	3.63	9.64	3.75

TUD42W2/D-D(U)

Outdoor air temperature °C		Indoor dry bulb temperature °C									
		16		18		20		22		24	
		TC	PI	TC	PI	TC	PI	TC	PI	TC	PI
DB	WB	kW	kW	kW	kW	kW	kW	kW	kW	kW	kW
-10	-11	11.16	4.73	10.58	4.87	10.10	5.04	9.68	5.21	9.23	5.38
-5	-5.6	11.05	4.23	10.47	4.35	10.00	4.50	9.59	4.65	9.14	4.80
0	-0.7	11.36	4.16	10.77	4.28	10.28	4.43	9.86	4.58	9.40	4.73
7	6	12.95	3.97	12.27	4.08	11.72	4.22	11.24	4.36	10.71	4.51
10	8	13.70	4.09	12.98	4.20	12.40	4.35	11.89	4.49	11.33	4.64

TUD48W2/D-D(U)

Outdoor air temperature °C		Indoor dry bulb temperature °C									
		16		18		20		22		24	
		TC	PI	TC	PI	TC	PI	TC	PI	TC	PI
DB	WB	kW	kW	kW	kW	kW	kW	kW	kW	kW	kW
-10	-11	12.83	6.07	12.16	6.24	11.62	6.46	11.14	6.67	10.62	6.90
-5	-5.6	12.71	5.42	12.04	5.57	11.50	5.77	11.03	5.96	10.51	6.16
0	-0.7	13.06	5.34	12.38	5.49	11.82	5.68	11.34	5.87	10.81	6.07
7	6	14.89	5.08	14.12	5.23	13.48	5.41	12.92	5.59	12.32	5.78
10	8	15.75	5.24	14.93	5.38	14.26	5.57	13.67	5.76	13.04	5.95

TUD60W2/D-D(U)

Outdoor air temperature °C		Indoor dry bulb temperature °C									
		16		18		20		22		24	
		TC	PI	TC	PI	TC	PI	TC	PI	TC	PI
DB	WB	kW	kW	kW	kW	kW	kW	kW	kW	kW	kW
-10	-11	15.07	5.78	14.29	5.94	13.64	6.15	13.08	6.35	12.47	6.57
-5	-5.6	14.92	5.16	14.14	5.30	13.51	5.49	12.95	5.67	12.35	5.86
0	-0.7	15.34	5.08	14.54	5.22	13.89	5.41	13.31	5.59	12.69	5.78
7	6	17.49	4.84	16.58	4.98	15.83	5.15	15.18	5.32	14.47	5.50
10	8	18.50	4.99	17.54	5.13	16.75	5.30	16.06	5.48	15.31	5.67

5 FAN CHARACTERISTICS

TUD24AH2/D-D(U)

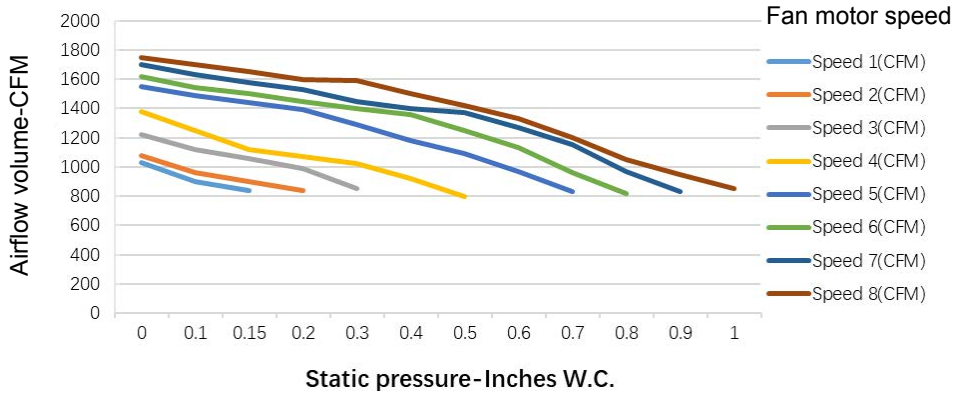

TUD30AH2/D-D(U)

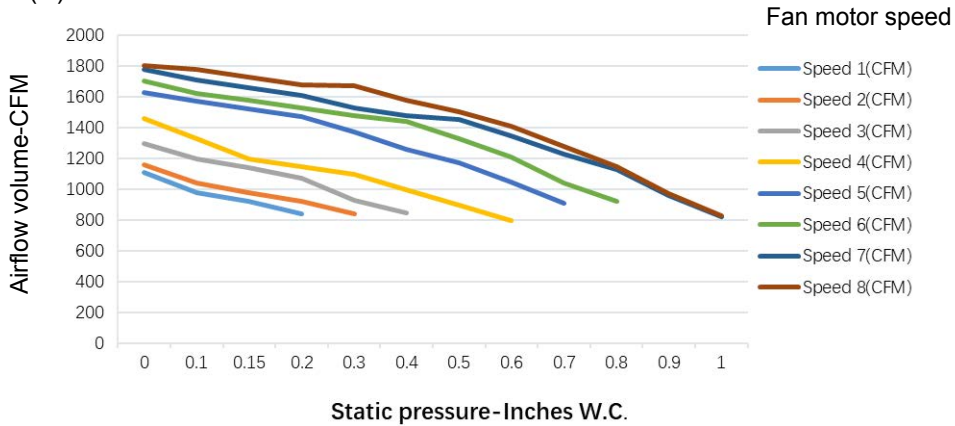

TUD36AH2/D-D(U)

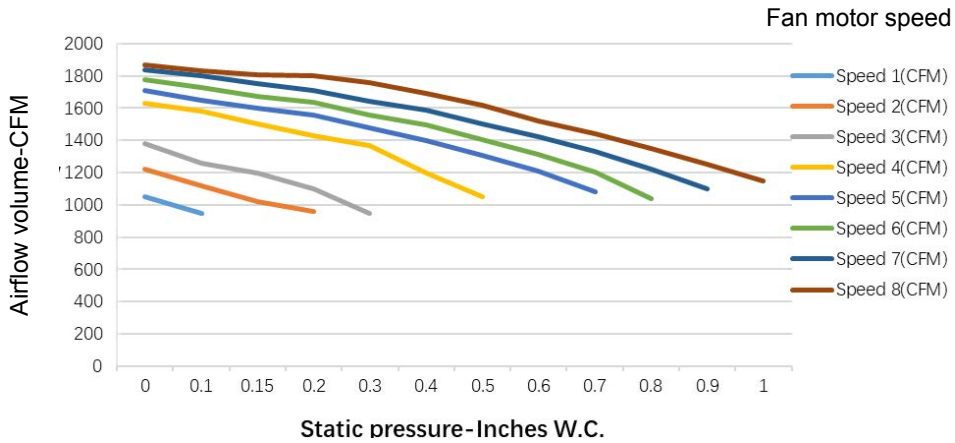

TUD42AH2/D-D(U)

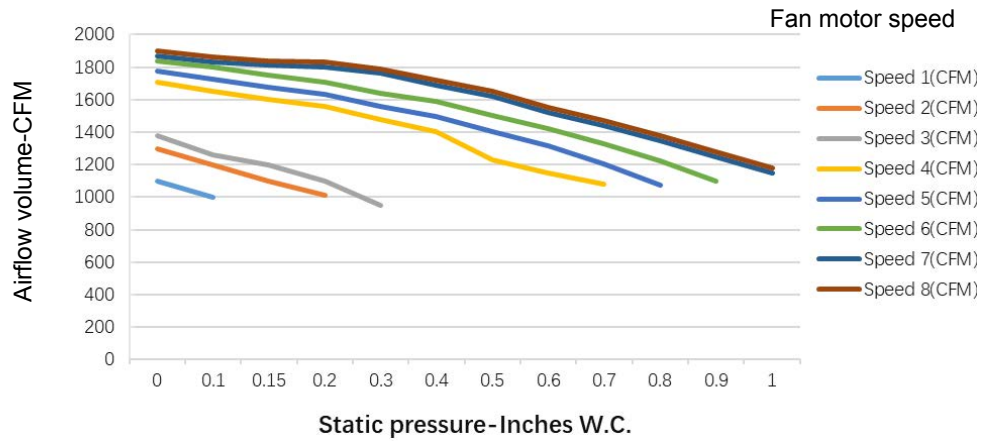

TUD48AH2/D-D(U)

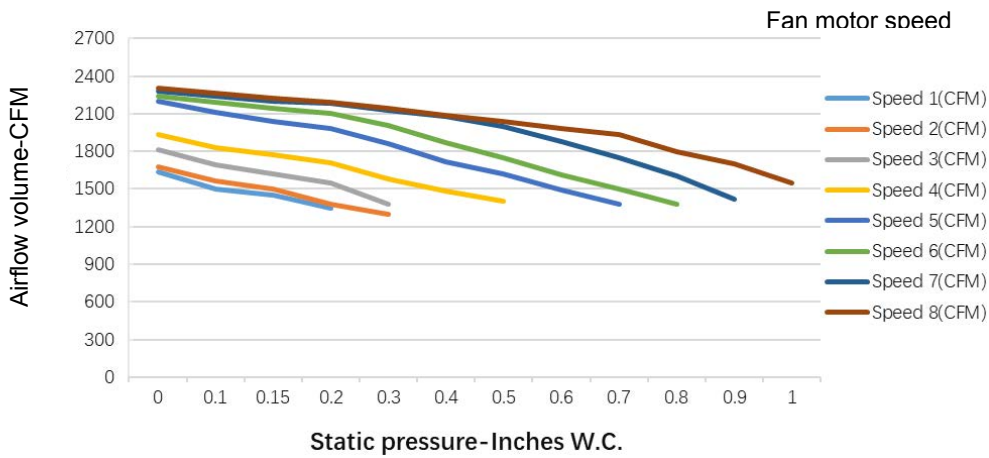

TUD60AH2/D-D(U)

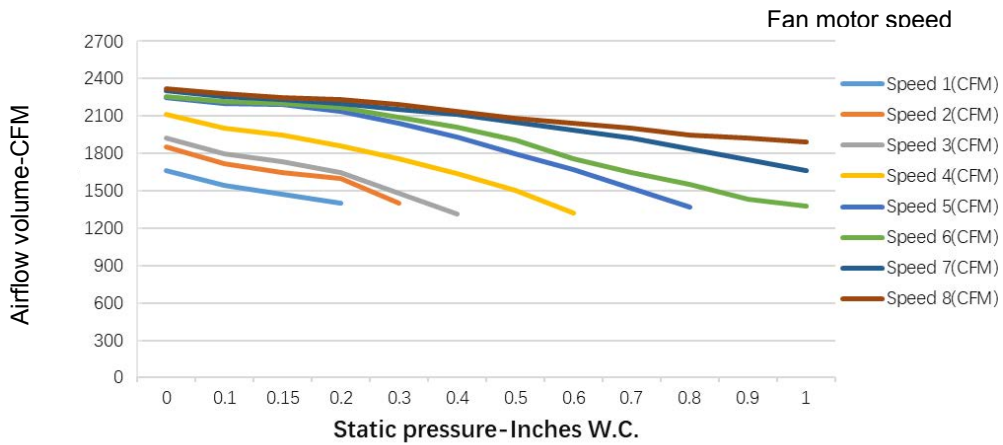

6 DIMENSION

➔ 6.1 Indoor Units

Air Handler

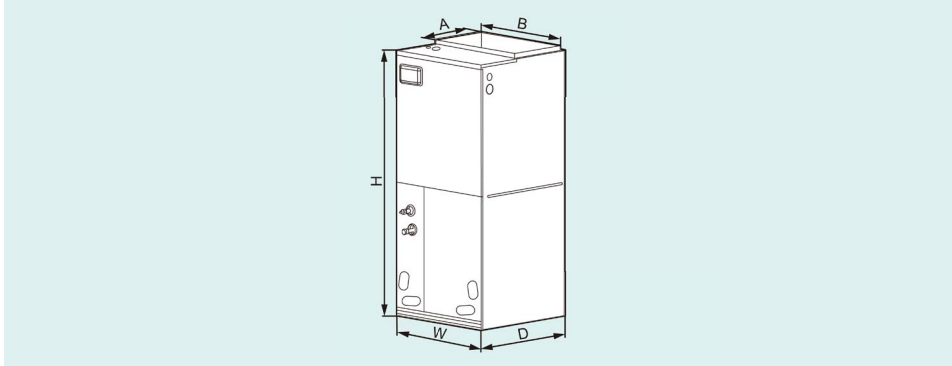

Unit: mm (inch)

Model	Dimension				
	W	D	H	A	B
TUD24AH2/D-D(U)	18-1/8	21-1/4	43-1/2	11-5/8	16-3/4
TUD30AH2/D-D(U)	(460)	(540)	(1105)	(295)	(426)
TUD36AH2/D-D(U)	21-1/4	21-1/4	48-3/16	11-5/8	20
TUD42AH2/D-D(U)	(540)	(540)	(1224)	(295)	(508)
TUD48AH2/D-D(U)	24-13/16	21-1/4	52	11-5/8	20
TUD60AH2/D-D(U)	(630)	(540)	(1320)	(295)	(508)

NOTE: When installing the air handler, take consideration to minimize the length of refrigerant tubing as much as possible. Do not install the air handler in a location either above or below the condenser that violates the instructions provided with the condenser. Service clearance is to take precedence. Allow a minimum of 24" in front of the unit for service clearance. When installing in an area directly over a finished ceiling (such as an attic), an emergency drain pan is required directly under the unit. See local and state codes for requirements. When installing this unit in an area that may become wet, elevate the unit with a sturdy, non-porous material. In installations that may lead to physical damage (i.e. a garage) it is advised to install a protective barrier to prevent such damage.

This air handler is designed for a complete supply and return ductwork system. Do not operate this product without all ductwork attached.

Based upon the actual conditions, if air handler is installed as Fig (A), the air handler should be concealed in a specific room or space and make sure the air handler is not accessible to the general public.

Based upon the actual conditions, if air handler is installed as Fig (B), make sure that there is enough space for care and maintenance and the height between the air handler and ground is above 2500mm. And the air handler is not accessible to the general public.

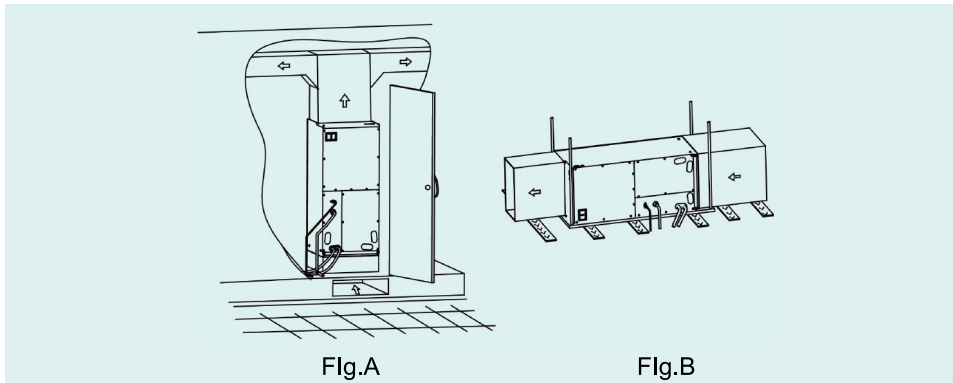

➔ 6.2 Outdoor Units

For TUD24W2/D-D(U), TUD30W2/D-D(U), TUD36W2/D-D(U), TUD42W2/D-D(U), TUD48W2/D-D(U), TUD60W2/D-D(U), unit:

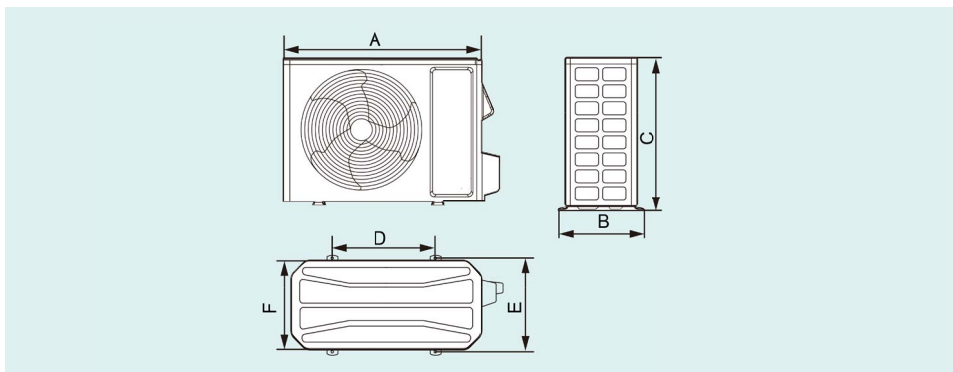

Unit: mm (inch)

Model	Item	A	B	C	D	E	F
TUD24W2/D-D(U)		35 (889)	15-13/16 (402)	25-7/8 (658)	22-7/16 (570)	14-9/16 (370)	13-3/8 (340)
TUD30W2/D-D(U)		36-5/16 (923)	16-13/16 (427)	29-3/8 (746)	24 (610)	15-9/16 (396)	14-9/16 (370)
TUD36W2/D-D(U)		37-1/8 (943)	16-13/16 (427)	32-1/2 (826)	25 (635)	15-9/16 (396)	14-9/16 (370)
TUD42W2/D-D(U)		39 (990)	16-13/16 (427)	37-13/16 (960)	29-3/4 (755)	15-9/16 (396)	14-9/16 (370)

DC INVERTER ROOFTOP PACKAGED AIR CONDITIONERS

Installation Location

1) When one outdoor unit is to be installed

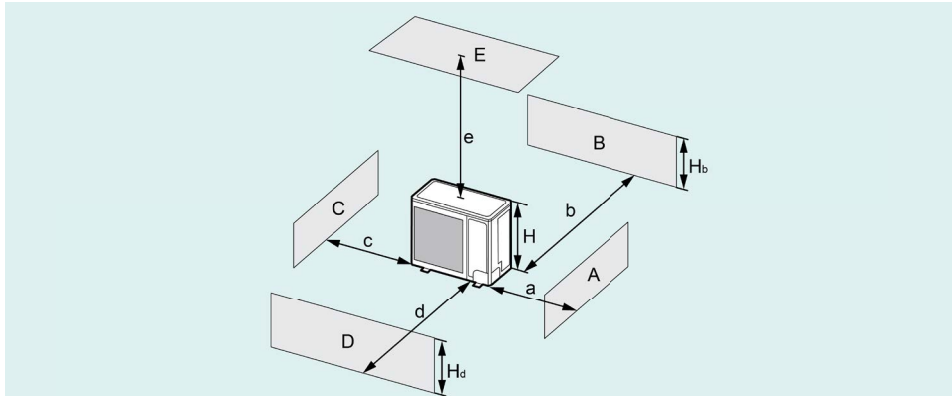

A~E	H _b H _d H		(mm)				
			a	b	c	d	e
B	—		—	≥ 100	—	—	—
A,B,C,	—		≥ 300	≥ 100	≥ 100	—	—
B,E	—		—	≥ 100	—	—	≥ 1000
A,B,C,E	—		≥ 300	≥ 150	≥ 150	—	≥ 1000
D	—		—	—	—	≥ 1000	—
D,E	—		—	—	—	≥ 1000	≥ 1000
B,D	H _b < H _d	H _d > H	—	≥ 100	—	≥ 1000	—
	H _b > H _d	H _d < H	—	≥ 100	—	≥ 1000	—
B,D,E	H _b < HD	H _b ≤ 1/2 H	—	≥ 250	—	≥ 2000	≥ 1000
		1/2 H < H _b ≤ H	—	≥ 250	—	≥ 2000	≥ 1000
		H _b > H	Prohibited				
	H _b > HD	H _d ≤ 1/2 H	—	≥ 100	—	≥ 2000	≥ 1000
		1/2 H < H _d ≤ H	—	≥ 200	—	≥ 2000	≥ 1000
		H _d > H	Prohibited				

2) When two or more outdoor units are to be installed side by side

Unit: mm

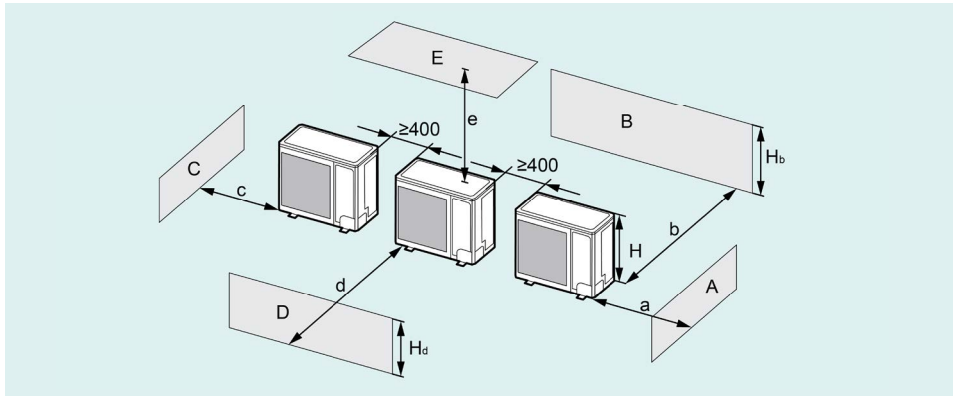

A~E	H _B H _D H		(mm)				
			a	b	c	d	e
A,B,C	—		≥ 300	≥ 300	≥ 1000	—	—
A,B,C,E	—		≥ 300	≥ 300	≥ 1000	—	≥ 1000
D	—		—	—	—	≥ 2000	—
D,E	—		—	—	—	≥ 2000	≥ 1000
B,D	HB < HD	H _D > H	—	≥ 300	—	≥ 2000	—
	HB > HD	H _D \leq 1/2 H	—	≥ 250	—	≥ 2000	—
		1/2 H < H _D \leq H	—	≥ 300	—	≥ 2500	—
B,D,E	HB < HD	H _B \leq 1/2 H	—	≥ 300	—	≥ 2000	≥ 1000
		1/2 H < H _B \leq H	—	≥ 300	—	≥ 2500	≥ 1000
		H _B > H	Prohibited				
	HB > HD	H _D \leq 1/2 H	—	≥ 250	—	≥ 2500	≥ 1000
		1/2 H < H _D \leq H	—	≥ 300	—	≥ 2500	≥ 1000
		H _D > H	Prohibited				

DC INVERTER ROOFTOP PACKAGED AIR CONDITIONERS

3) When outdoor units are installed in rows

Unit: mm

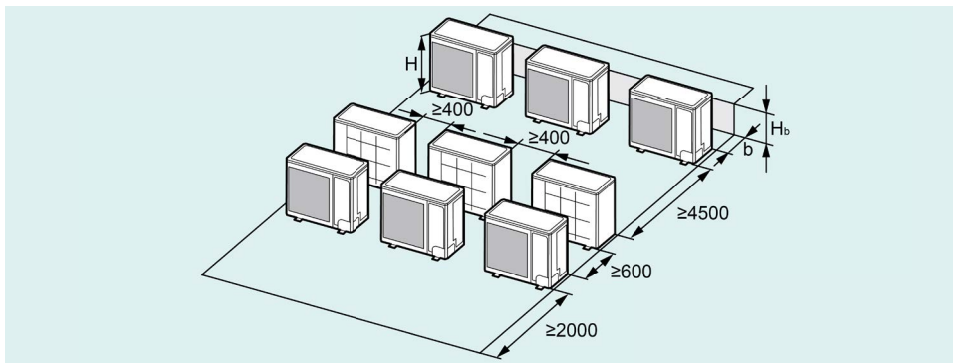
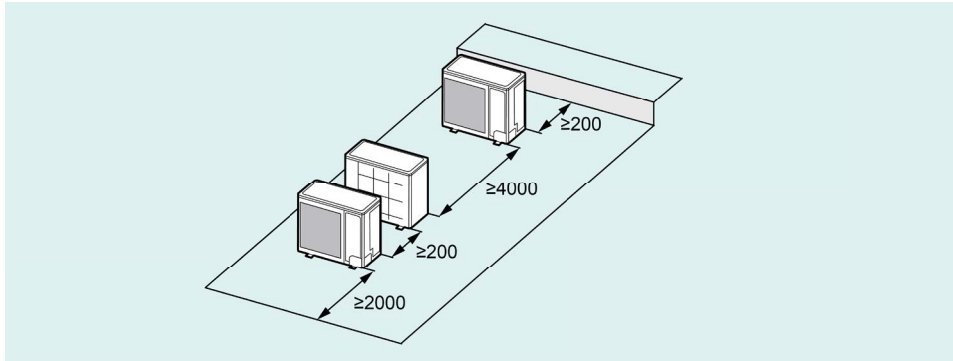

H_b H	(mm)
$H_b \leq 1/2 H$	$b \geq 250$
$1/2 H < H_b \leq H$	$b \geq 300$
$H_b > H$	Prohibited

4) When outdoor units are installed one above another

Unit: mm

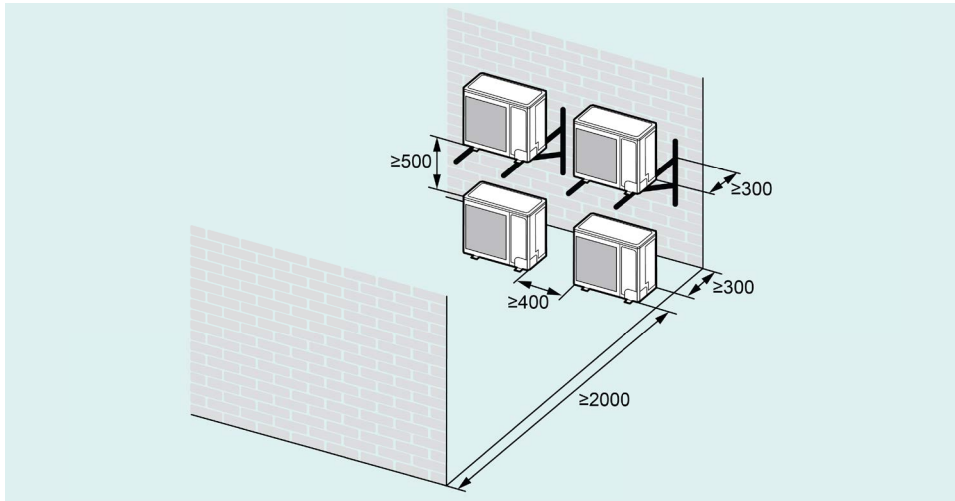

➔ 6.3 Dimension – Controller

Thermostat (Optional)

Unit: mm

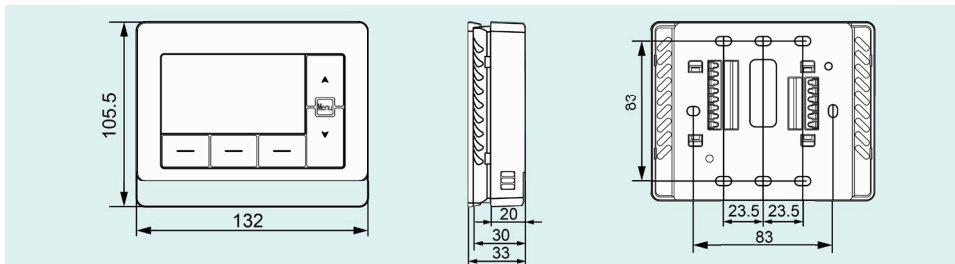

7 WIRING DIAGRAM

7.1 Field Wiring Diagrams

Outdoor Units
 For TUD24W2/D-D(U), TUD30W2/D-D(U), TUD36W2/D-D(U) unit:

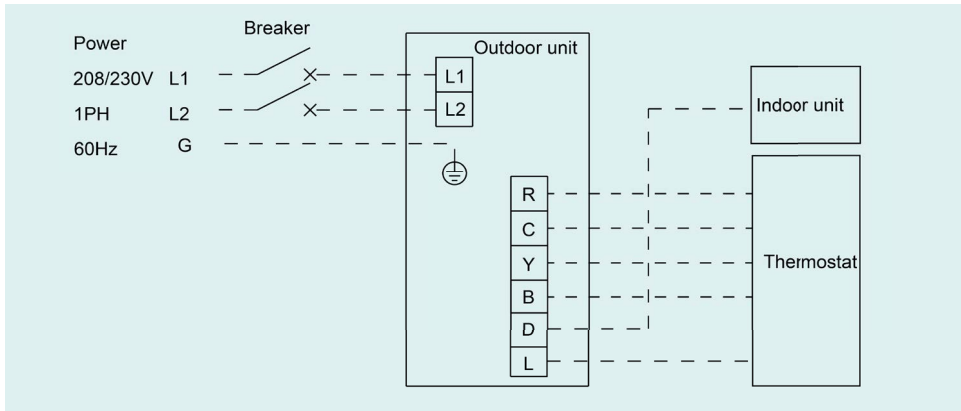
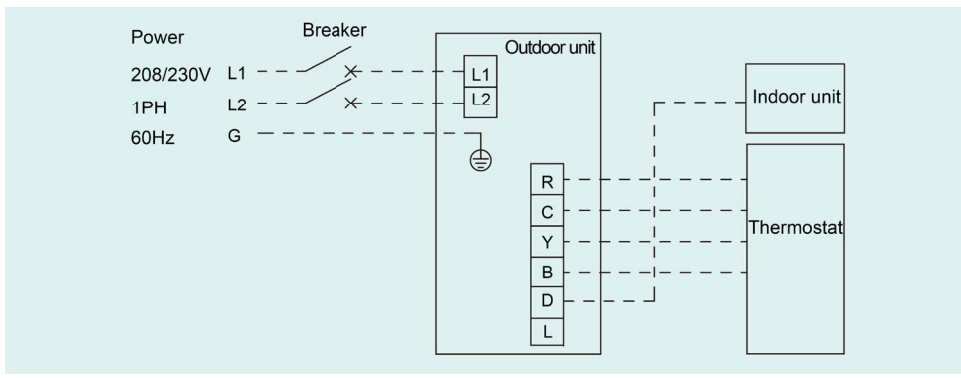

Air Handler

For TUD24AH2/D-D(U), TUD30AH2/D-D(U), TUD36AH2/D-D(U) unit:

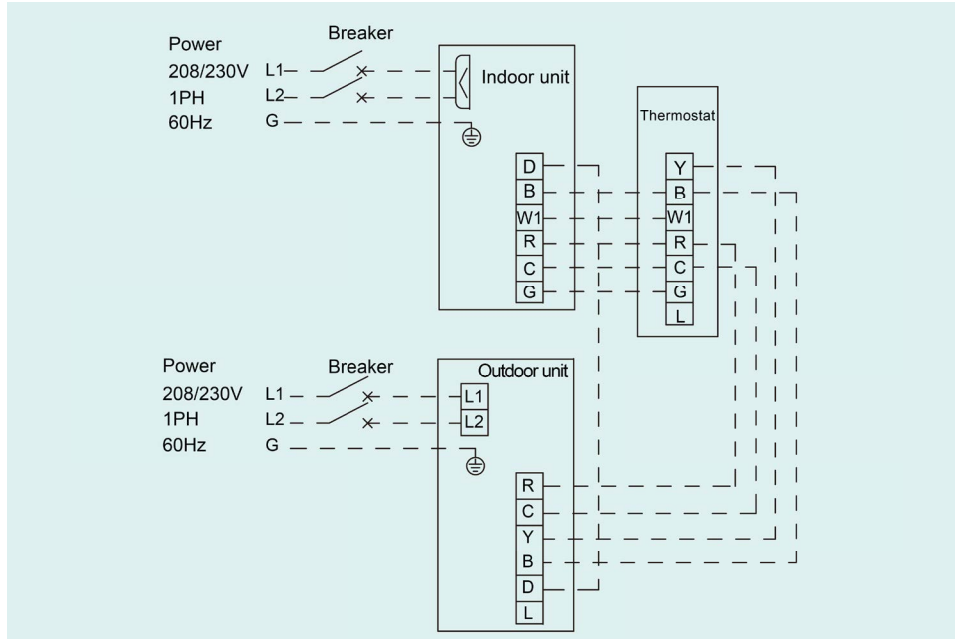

For TUD42AH2/D-D(U), TUD48AH2/D-D(U), TUD60AH2/D-D(U) unit:

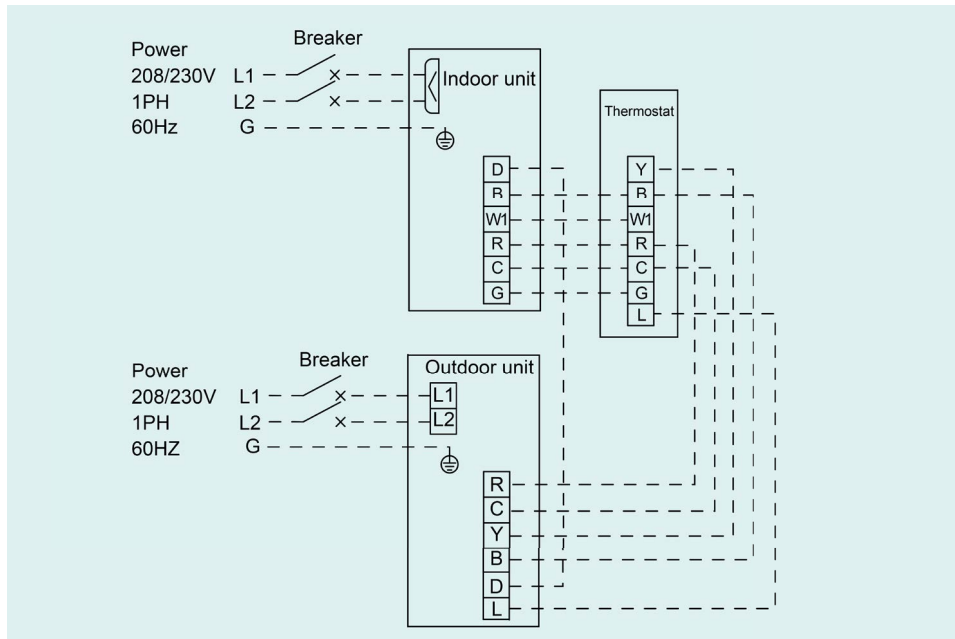

NOTE:

- Y means Compressor control signal for the outdoor unit;
- B which is energized under the heating mode means 4-way valve control signal;
- D means defrosting signal;
- R means 24V AC power supply;
- C means 24V common;

DC INVERTER ROOFTOP PACKAGED AIR CONDITIONERS

G means indoor unit fan signal for the indoor unit;

W1 means heater control signal;

L reserved function.

NOTE: 1.For cooling only unit, there is no need to connect the B and D terminals.

2.When outdoor defrosts, D of outdoor unit will send 24V signal to avoid cold winds.

3.L reserved function, the wiring board does not pick up.



7.2 Specification of Power Supply Wire and Air Switch

7.2.1 Outdoor Units

Model	Power Supply	Fuse Capacity	Minimum Circuit Ampacity	Maximum Overcurrent Protection
	V / Ph / Hz	A	A	A
TUD24W2/D-D(U)	208/230V-1Ph-60Hz	20	17	20
TUD30W2/D-D(U)	208/230V-1Ph-60Hz	25	20	25
TUD36W2/D-D(U)	208/230V-1Ph-60Hz	30	22.5	30
TUD42W2/D-D(U)	208/230V-1Ph-60Hz	35	25.5	35
TUD48W2/D-D(U)	208/230V-1Ph-60Hz	40	29	40
TUD60W2/D-D(U)	208/230V-1Ph-60Hz	45	32	45

7.2.2 Indoor Units

Air Handler

Model	Power Supply V / Ph / Hz	Minimum Circuit Ampacity	Maximum Overcurrent Protection
		A	A
TUD24AH2/D-D(U)	208/230V-1Ph-60Hz	1.8	15
TUD30AH2/D-D(U)		3.2	
TUD36AH2/D-D(U)		4	
TUD42AH2/D-D(U)		4.3	
TUD48AH2/D-D(U)		6.9	
TUD60AH2/D-D(U)		7.5	



TOSOT.COM

Address: supply circuit should be used in
902 344 5578
Email: regulations and National Electrical Code
ly sized circuit breaker to protect equipment
against short circuit and