



MULTI-ROOM DUCTLESS SYSTEMS

9000 BTU / H MINI FLOOR CONSOLE UNIT

SUBMITTAL DATA: TM09HEDI

Job Name	Location	Date
Purchaser	Engineer	
Submitted To	For	<input type="checkbox"/> Reference <input type="checkbox"/> Approval <input type="checkbox"/> Construction
Unit Designation	Schedule No.	



GENERAL FEATURES

- Quiet Operation -Multi-Speed Fan
- Swing Louvers
- Wireless Remote Controller
- Remote Control Lockout
- Limited 10 Year Parts & 10 Years Compressor Warranty-Residential & Commercial

SYSTEM RATINGS		PHYSICAL SPECIFICATIONS	
Cooling*		Unit Dimensions (LxHxD)	27.5 x 24.0 x 8.5 -in 700 x 600 x 215-mm
Rated Capacity	8,874 BTU/H	Weight (Net/Shipping)	33/40 LBS
Heating*		Drain Size (OD)	0.67-in 17-mm
Rated Capacity	9,556 BTU/H		
Sound Level (Hi/Lo)**			
Cooling	40/25 dbA		
Heating	40/25 dbA		
Air Flow (max)			
Indoor Fan CFM	294 CFM		
* Capacity based on diversity of all connected units and the OD Unit			
ELECTRICAL RATINGS		REFRIGERANT PIPING DATA	
Fan Motor		Refrigerant Type	R410A
Output Power	30 W	Gas Pipe Size (OD)	3/8-in
FLA	0.36 A	Liquid Pipe Size (OD)	1/4-in
Power Supply		Connection Method	Flared
Normal Operational Voltage	208/230 V, 1 Phase, 60 Hz	* Test conditions are based on AHRI 210/240. **Sound Pressure ratings are per AHRI 270 and AHRI 350	
Voltage Range	187 - 253 V		
MCA	1.0 A		
Interconnecting Cable Wire Size	14-4 AWG		

DIMENSIONAL SPECIFICATIONS: TM09HEDI

9,000 BTUH MODEL

Model : TM09HEDI 9,000 BTUH 230V

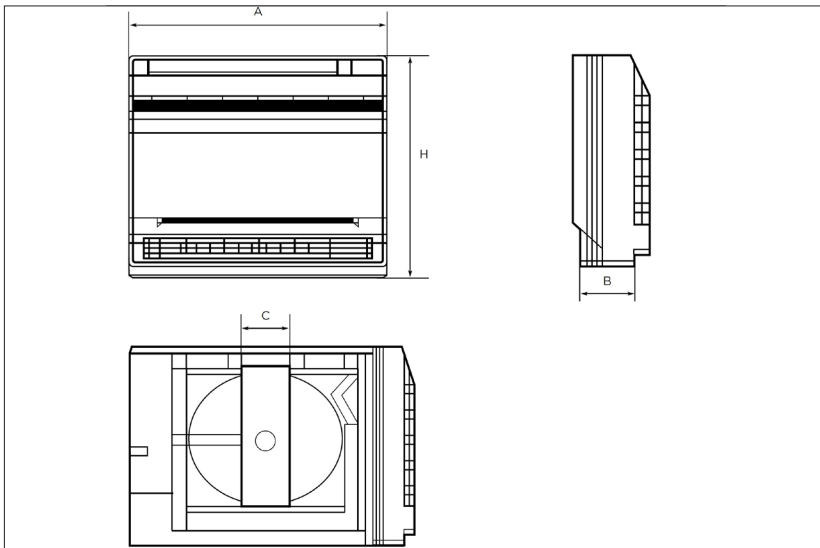

Dimensions				
	A	B	C	H
mm	700	215	200	600
in	27.6	8.5	7.875	23.6

Note: Size refrigerant lines based on evaporator port sizes.

MINIMUM & MAXIMUM CLEARANCES

Wc = inches of water column

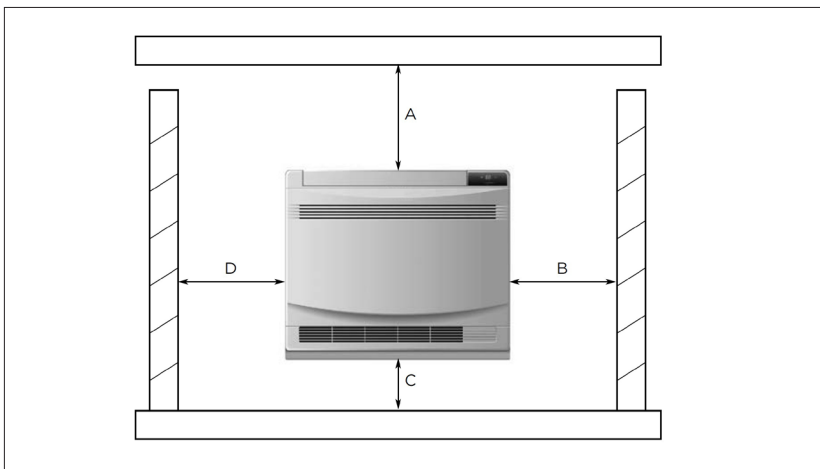

Dimensions				
	A	B	C	D
mm	1500	610	150	610
in	59	24	6	24

Notes:

1. Recommended Interconnecting Cable Type 14 AWG 4 Stranded Copper Conductors Wire.
2. Power wiring cable size must comply with applicable national and local codes.
3. Test conditions are based on AHRI 210/240.